

**THE ZPOD:
A GRAVIMETRIC
MASS FLUCTUATION
SYSTEM**

REV. 5.0

William Alek
INTALEK, INC.

3506-43rd. Place
Highland, IN
46322

CONTACT INFO:
PHONE: 219.924.2742
EMAIL: alekws@intalek.com

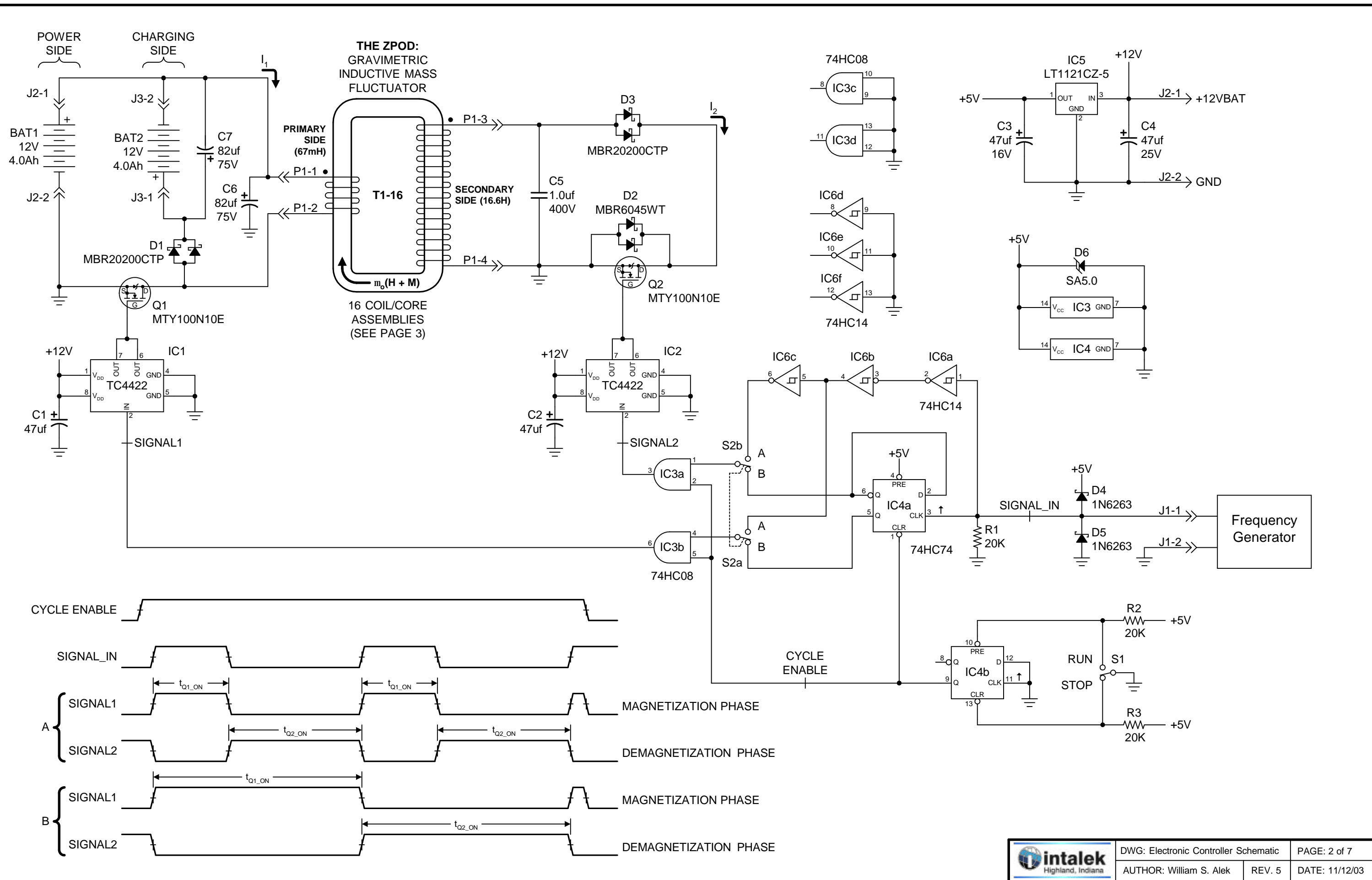

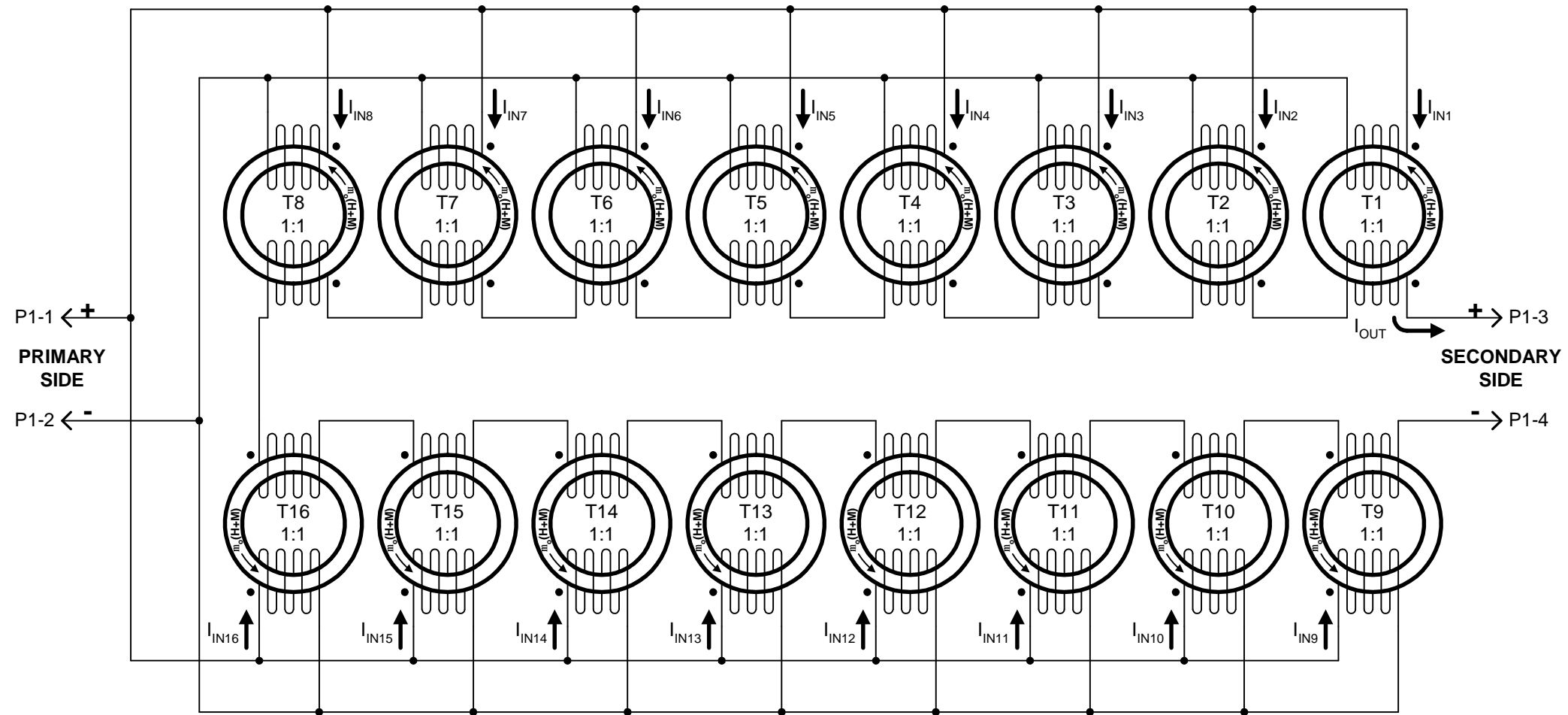

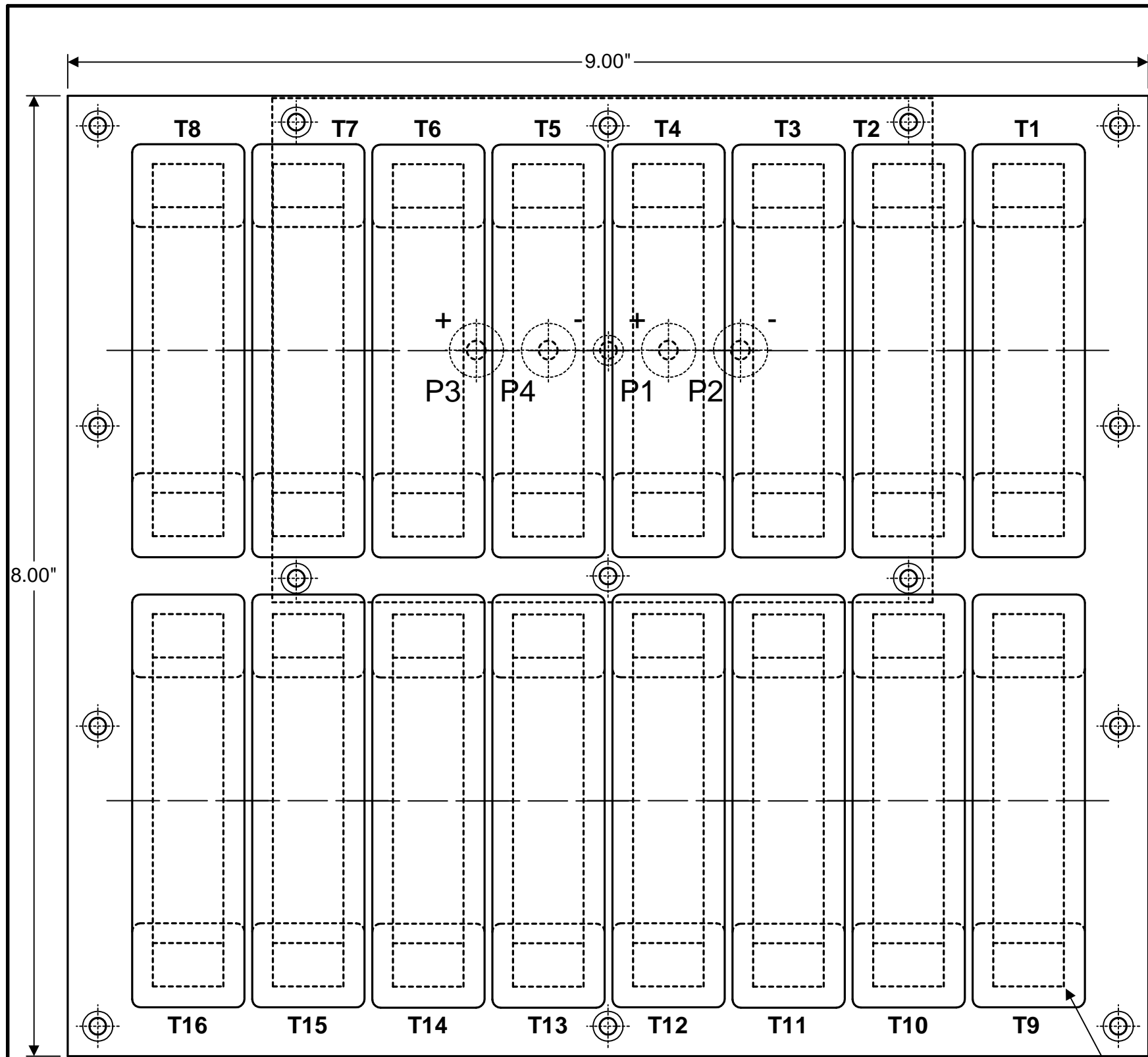

TOP VIEW
(SECONDARY COIL CIRCUIT BOARD NOT SHOWN)

PERMALLOY
CORES

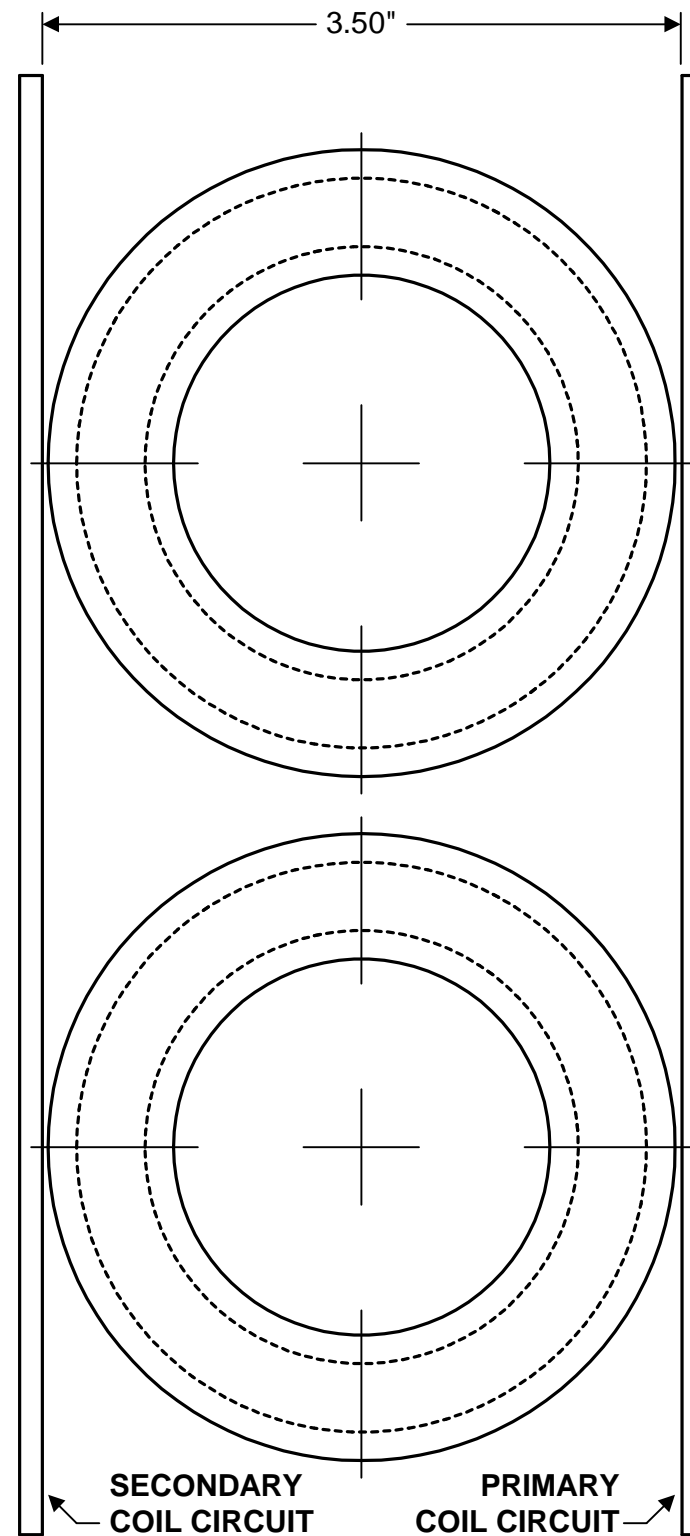

SIDE VIEW

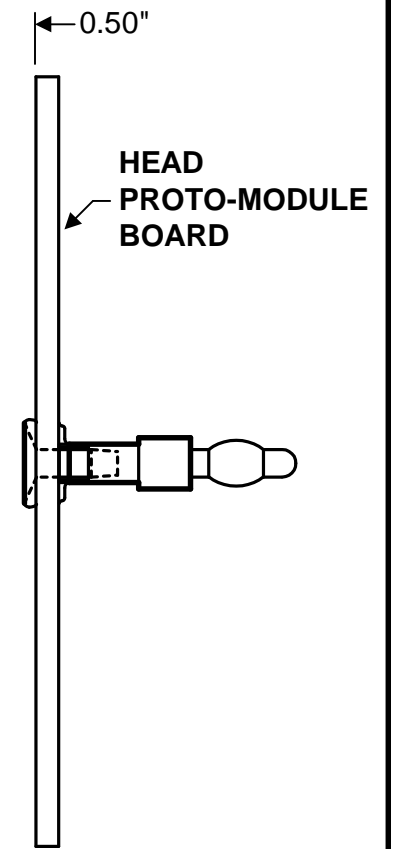

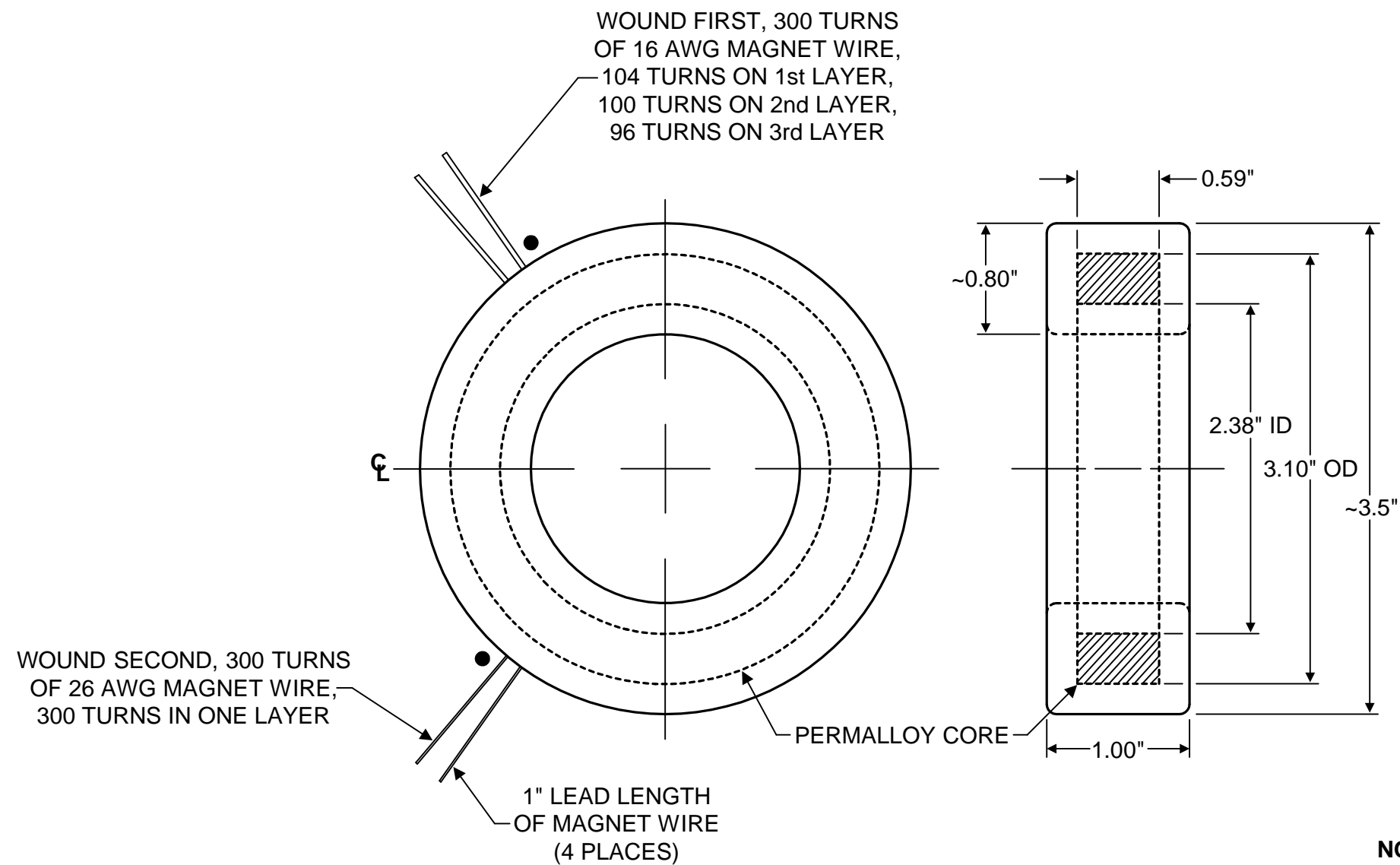

QTY: 16 CORE ASSY'S REQ'D

NOTE 1: BOTH WIRE COILS ARE WOUND IN THE SAME DIRECTION.

NOTE 2: CORE MFR: Magnetics Inc.
CORE PART NO.: 50031-1D

NOTE 3: WINDING SERVICE:
ELECTRO ASSEMBLIES CORP.
DWG NO.: 430106

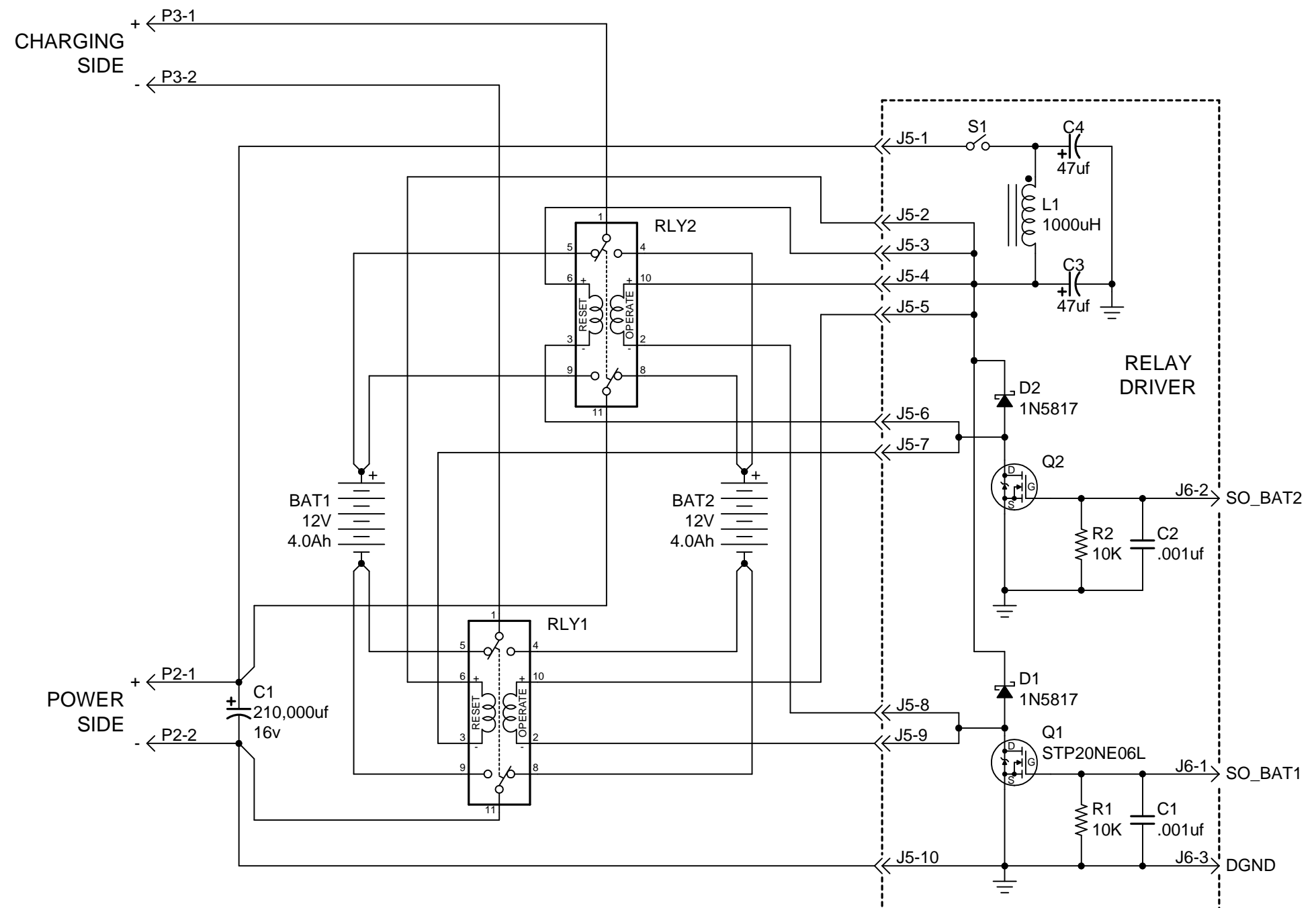

PULSED INPUT	RLY1 & RLY2 STATE	RLY1 & RLY2 PINS	SELECT OUTPUT
SO_BAT1	OPERATE	1-4; 11-9	BAT1
SO_BAT2	RESET	1-5; 11-8	BAT2

NOTE: Relays RLY1 and RLY2 are magnetic latching type.

